

NOTE: A 2 FT. WIDE CONCRETE LEAKOFF SLOPED AT 1/2":1' FROM SIDEWALK TO CURB SHALL BE PROVIDED TO ALLOW STORM WATER TO DRAIN FROM THE SIDEWALK AT LOW POINTS WHERE THERE IS NOT AN ADJACENT DRIVEWAY OR HANDICAP RAMP.

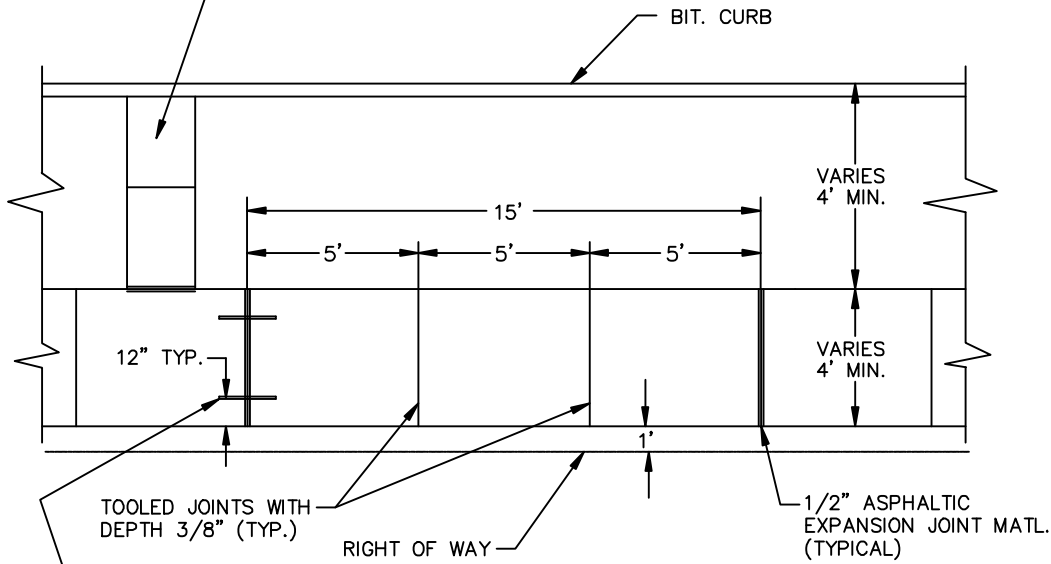

NOTE: DOWELS SHALL BE PLACED AT CONSTRUCTION JOINTS AND WHERE NEW CONCRETE MEETS EXISTING CONCRETE (SEE DETAIL).

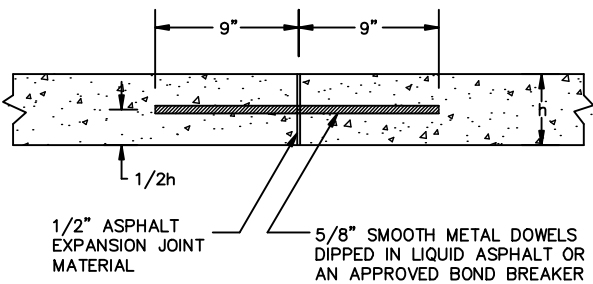
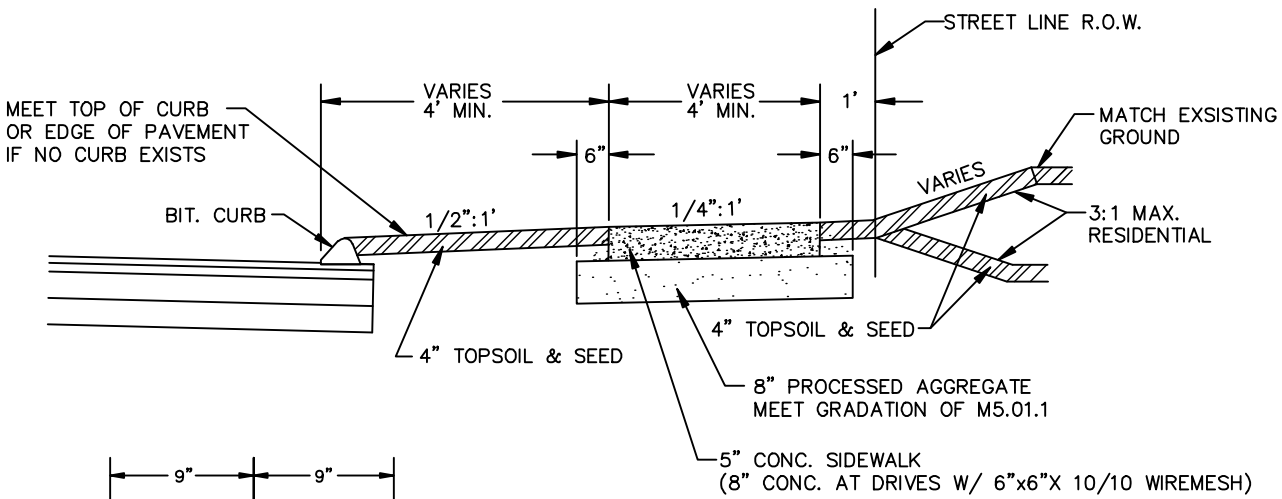

EXPANSION JOINT - DETAIL

NOT TO SCALE

TOWN OF SOUTH WINDSOR
STANDARD DETAIL

MARCH, 2005

TYPICAL SIDEWALK DETAIL

REVISED:

APPROVED

PUBLIC WORKS DIRECTOR